

## Ultra Fast Silicon Mesa Rectifiers

### Features

- Controlled avalanche characteristic
- Low forward voltage
- Ultra fast recovery time
- Glass passivated junction
- Hermetically sealed package

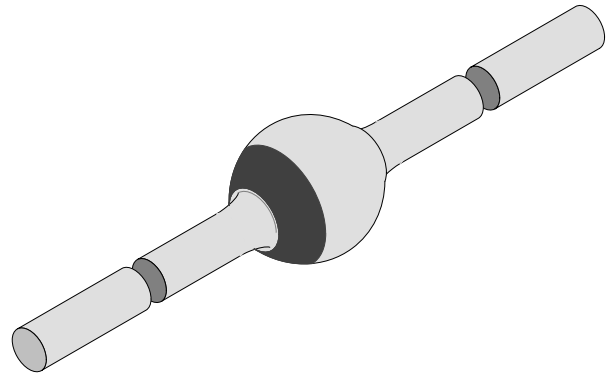

94 9588

### Applications

Very fast rectifier e.g. for switch mode power supply

### Absolute Maximum Ratings

$T_j = 25^\circ\text{C}$

Parameter	Test Conditions	Type	Symbol	Value	Unit
Peak reverse voltage, non repetitive		BYV28/50	$V_{RSM}$	55	V
		BYV28/100	$V_{RSM}$	110	V
		BYV28/150	$V_{RSM}$	165	V
		BYV28/200	$V_{RSM}$	220	V
Reverse voltage		BYV28/50	$V_R = V_{RRM}$	50	V
		BYV28/100	$V_R = V_{RRM}$	100	V
		BYV28/150	$V_R = V_{RRM}$	150	V
		BYV28/200	$V_R = V_{RRM}$	200	V
Peak forward surge current	$t_p = 10\text{ms}$		$I_{FSM}$	90	A
Repetitive peak forward current			$I_{FRM}$	25	A
Average rectifier output current			$I_{FAV}$	3.5	A
Max. pulse energy in the avalanche mode, non repetitive (inductive load switch off)	$I_{(BR)R} = 0.6\text{A}$ , $T_j = 175^\circ\text{C}$		$E_R$	20	mWs
Junction temperature			$T_j$	175	$^\circ\text{C}$
Storage temperature range			$T_{stg}$	-65...+175	$^\circ\text{C}$

### Maximum Thermal Resistance

$T_j = 25^\circ\text{C}$

Parameter	Test Conditions	Symbol	Value	Unit
Junction ambient	$l = 10\text{mm}$ , $T_L = \text{constant}$	$R_{thJA}$	25	K/W
	on PC board with spacing 37.5 mm	$R_{thJA}$	70	K/W

### Characteristics

$T_j = 25^\circ\text{C}$

Parameter	Test Conditions	Type	Symbol	Min	Typ	Max	Unit
Forward voltage	$I_F=5\text{A}$		$V_F$			1.1	V
	$I_F=5\text{A}, T_j=175^\circ\text{C}$		$V_F$			0.89	V
Reverse current	$V_R=V_{RRM}$		$I_R$			1	$\mu\text{A}$
	$V_{RSM}$		$I_R$			100	$\mu\text{A}$
	$V_R=V_{RRM}, T_j=165^\circ\text{C}$		$I_R$			150	$\mu\text{A}$
Reverse recovery time	$I_F=0.5\text{A}, I_R=1\text{A},$ $i_R=0.25\text{A}$		$t_{rr}$			30	ns

## Typical Characteristics ( $T_j = 25^\circ\text{C}$ unless otherwise specified)

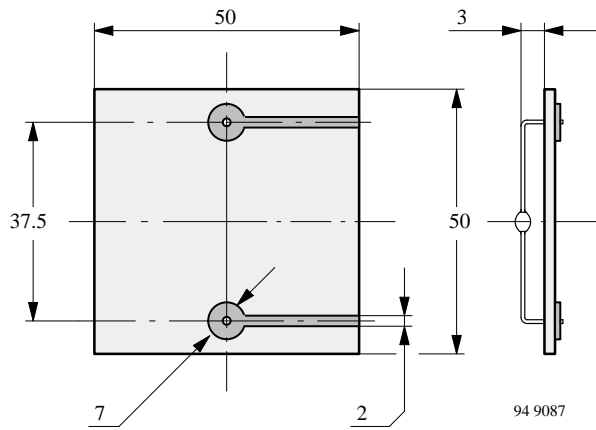

Figure 1 : Epoxy glass hard tissue, board thickness 1.5 mm,  
 $R_{thJA} \leq 70 \text{ K/W}$

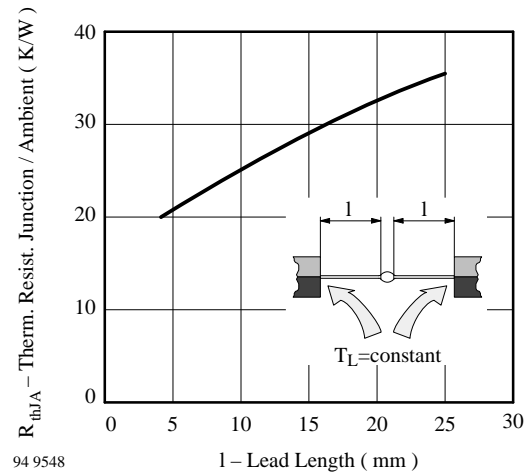

Figure 2 : Thermal Resistance vs. Lead Length

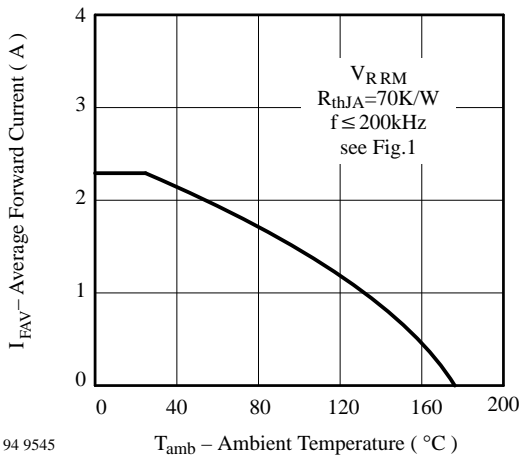

Figure 3 : Average Forward Current vs. Ambient Temperature

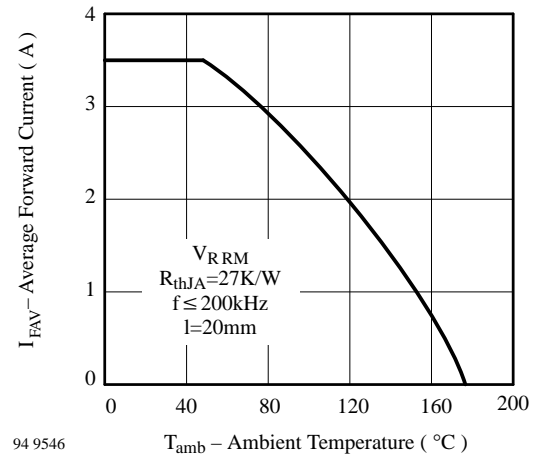

Figure 4 : Average Forward Current vs. Ambient Temperature

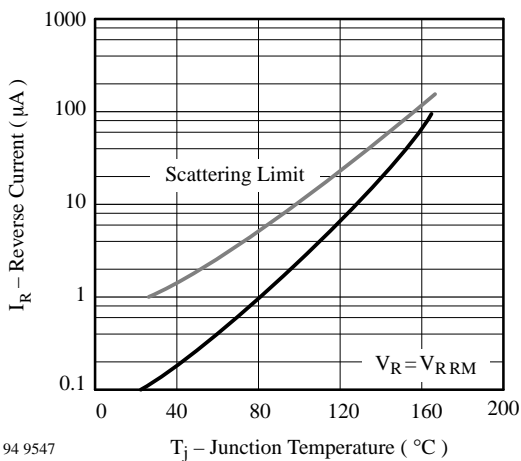

Figure 5 : Reverse Current vs. Junction Temperature

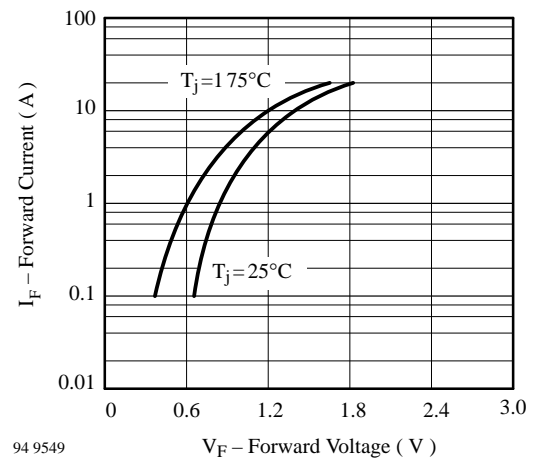
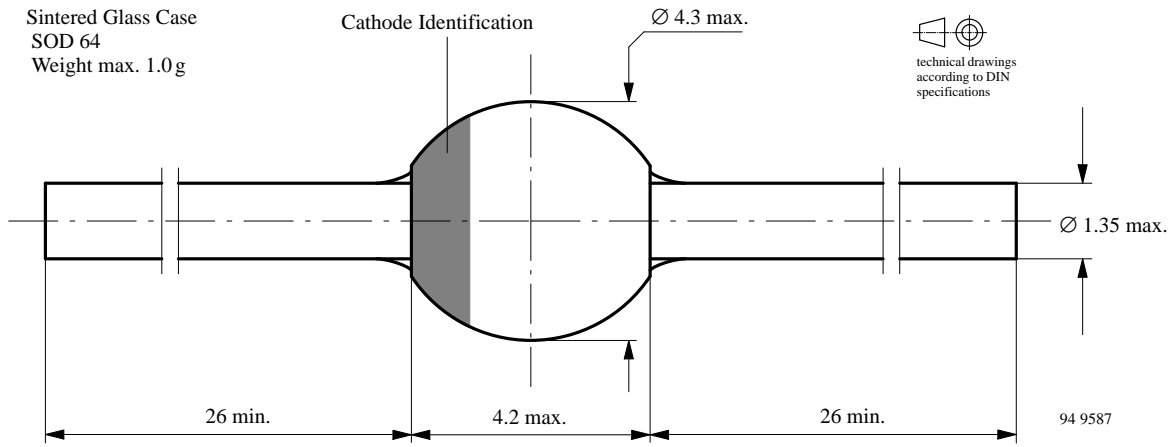

Figure 6 : Forward Current vs. Forward Voltage

## BYV28/...

### Dimensions in mm

Sintered Glass Case  
SOD 64  
Weight max. 1.0 g



---

## OZONE DEPLETING SUBSTANCES POLICY STATEMENT

It is the policy of **TEMIC TELEFUNKEN microelectronic GmbH** to

1. Meet all present and future national and international statutory requirements and
2. Regularly and continuously improve the performance of our products, processes, distribution and operating systems with respect to their impact on the health and safety of our employees and the public, as well as their impact on the environment.

Of particular concern is the control or elimination of releases into the atmosphere of those substances which are known as ozone depleting substances (ODSs).

The Montreal Protocol (1987) and its London Amendments (1990) will soon severely restrict the use of ODSs and forbid their use within the next ten years. Various national and international initiatives are pressing for an earlier ban on these substances.

**TEMIC TELEFUNKEN microelectronic GmbH** semiconductor division has been able to use its policy of continuous improvements to eliminate the use of any ODSs listed in the following documents.

1. Annex A, B and list of transitional substances of the Montreal Protocol and the London Amendments respectively
2. Class I and II ozone depleting substances in the Clean Air Act Amendments of 1990 by the Environmental Protection Agency (EPA) in the USA and
3. Council Decision 88/540/EEC and 91/690/EEC Annex A, B and C (transitional substances) respectively.

**TEMIC** can certify that our semiconductors are not manufactured with and do not contain ozone depleting substances.

**We reserve the right to make changes to improve technical design without further notice.**

Parameters can vary in different applications. All operating parameters must be validated for each customer application by the customer. Should the buyer use TEMIC products for any unintended or unauthorized application, the buyer shall indemnify TEMIC against all claims, costs, damages, and expenses, arising out of, directly or indirectly, any claim of personal damage, injury or death associated with such unintended or unauthorized use.

TEMIC TELEFUNKEN microelectronic GmbH, P.O.B. 3535, D-74025 Heilbronn, Germany  
Telephone: 49 (0)7131 67 2831, Fax Number: 49 (0)7131 67 2423